

KSE

Vite testa a martello
Hammer head screw

Combinazioni
di cablaggio
Wiring combinations

sistema brevetto
patent system
VI2015A000094



LAFER

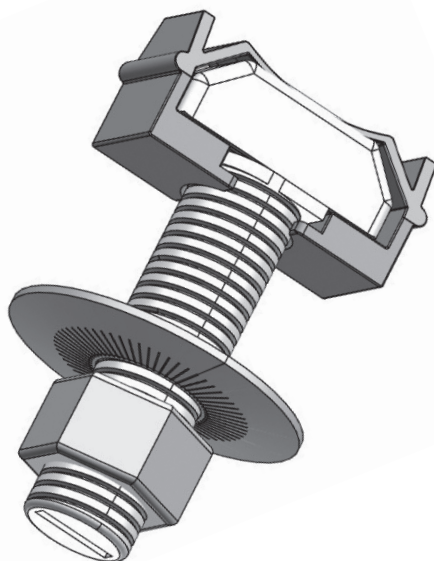

Lafer Srl
36040 Meledo di Sarego (Vicenza) - Italy
Customer service (+39) 0444 490562 - Fax (+39) 0444 695863
lafer@lafer.it

lafer.com

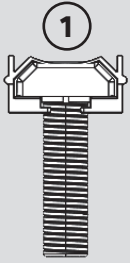

3/Z0864

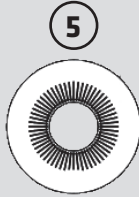

3/4608L



mm 13

kit ① + ④ + ⑤	KSE/25 pz 20 M8x25
	KSE/30 pz 20 M8x30
	KSE/40 pz 20 M8x40

Elementi **non inclusi** nei kit KSE, acquistabili separatamente
Items **not included** in KSE kit, they can be purchased separately

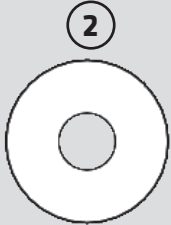

ROM08/C pz20

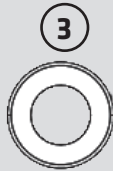

3/P4608



IFN/C pz32
(8+8+8+8)



TIV8/C pz100

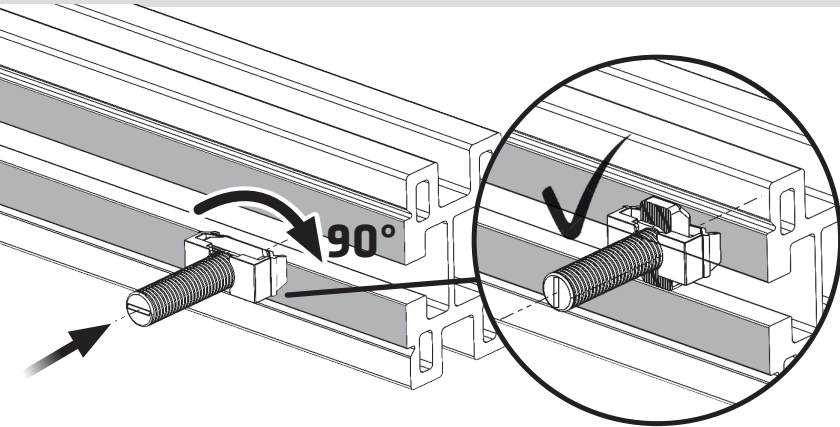

inserimento vite e rotazione da effettuare prima del cablaggio

screw insertion and rotation to be carried out before the wiring stage

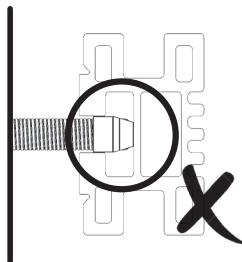
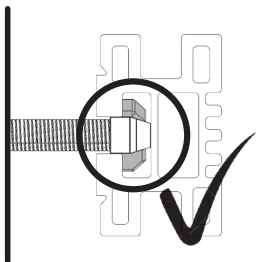

28 Nm
coppia di serraggio
max tightening torque

KIT di Giunzione Smart Energy *Smart Energy coupling KIT*

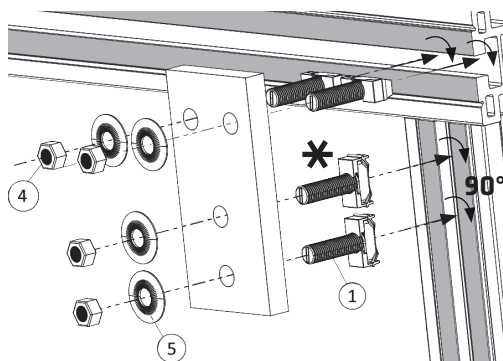

AWG < 25mm²

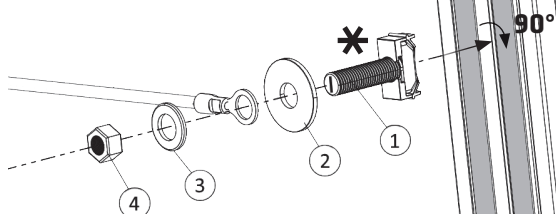

AWG > 25mm²

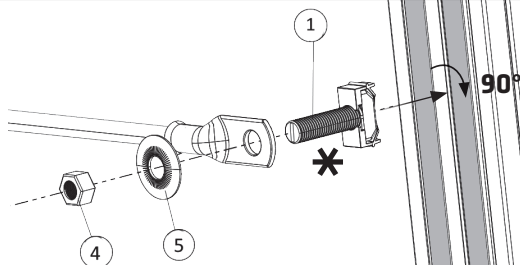

Barre/Trecce Flessibili Isolate *Bars/Insulated flexible braids*

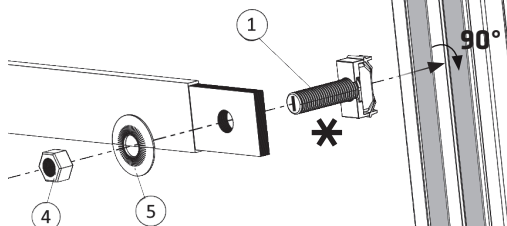

Barratura Rigida *Rigid bar*

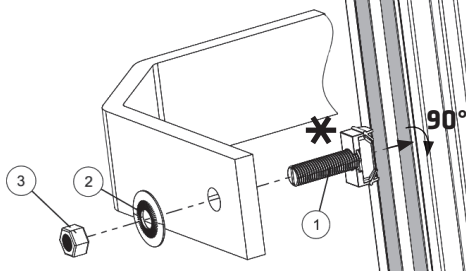

Esempio di applicazione con capicorda M10

Example of use with M10 terminals.

Alcuni elementi rappresentati nel disegno sono fatti su misura in fase di cablaggio e non disponibili nel catalogo Lafer.

Some of the items here depicted are tailor-made for specific applications throughout the wiring stage. They are not available in Lafer product catalogue.

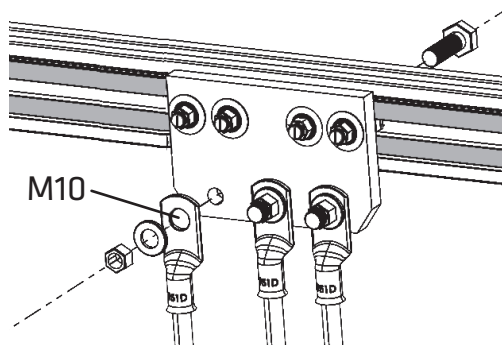

Articoli correlati

Related items

Tappo isolamento

Insulating cap

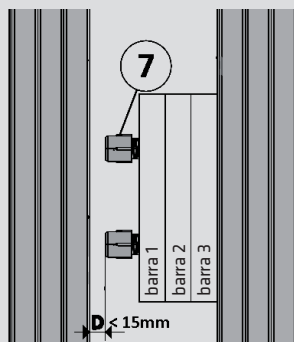
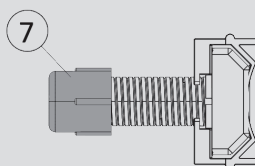

Identificatore Fasi

Phases identifier

